

TOP VIEW

- 1) FLANGE MOUNT BLAYLOCK LL10 P/V VENT
160Z SETTING, BAKER SPEC
- 2) 4" FLANGE WITH BLIND CAP AND CHAIN
- 3) 2" COUPLING WITH PLUG
- 4) MANWAY WITH INTERNAL BARS, 21 1/2"ID, DOMED LID
- 5) 3" NIPPLE WITH CAP AND CHAIN
- 6) SAFETY WALK WAY
- 7) ACCESS STAIRS
- 8) LEVEL GAUGE W/2-8" STAINLESS STEEL BALL
"Y" SUPPORT HOLDS BALLS 1/2" OFF FLOOR
- 9) FRONT DRAIN W/VALVE, PLUG, CHAIN
- 10) MANWAY, 21 1/2"ID, DOMED LID (2)
- 11) 11.00 X 22.5 TUBLESS TIRE ON 10 HOLE STEEL WHEEL
- 12) 4" FLANGE, VALVE, THREADED FLANGE, PLUG, CHAIN
REMOTE OPERATION HANDLE
- 13) 25K AXLE, AUTOMATIC SLACK ADJUSTERS, TOP MOUNTED
30 SERVICE CHAMBERS, OUTBOARD DRUMS, HUTCH
9700 SUSPENSION, 3 LEAF HIGH ARCH SPRINGS
- 14) DOT TAIL LIGHTS AND LOWER MARKER LIGHTS, NO TOP LIGHTS
- 15) 1" X 6" PIPE W/WELDED CAP & THREADED CAP
- 16) FOLDING HAND RAILS
- 17) 48x48 BOLTED PLATE (for Baker Decal)

NOTE:
ALL VALVES BRAY SERIES 30, CAST IRON BODY,
416SS STEM, BUNA-N SEAT, NYLON 11 COATED
DUCTILE IRON DISC, HANDLES AS SHOWN.
ALL WALL AND ROOF RIBS TO BE CONTINUOUSLY
WELDED, ALL TANK SHELL SEAMS TO BE WELDED
ON BOTH SIDES.
100% CAPACITY WATER TEST @ 3 PSI
SOME ITEMS MAY NOT BE SHOWN IN ALL VIEWS

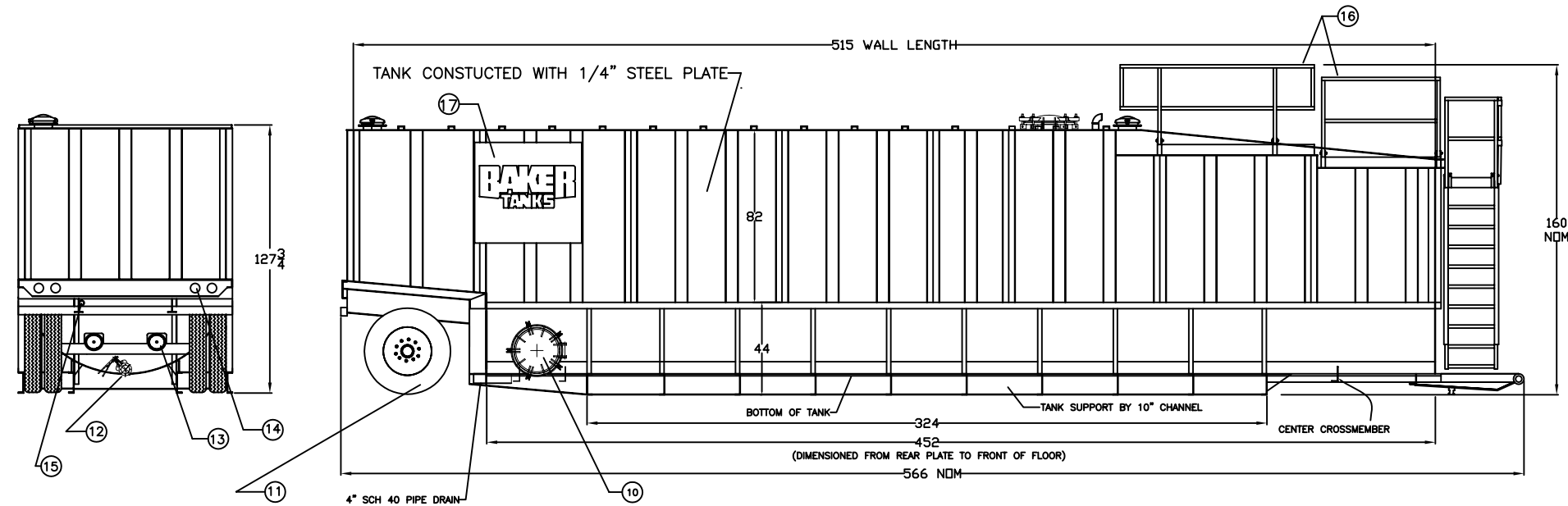

SIDE VIEW

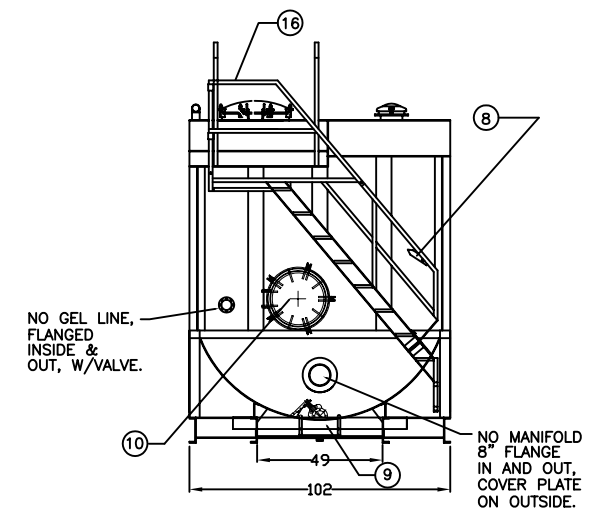

FRONT VIEW

NOTES:
STAIRS FITTED WITH LOWER 1/2 WIDTH SECTION
REMOVABLE TO REPLACE WITH FULL WIDTH STEP OPTION

SPECIFICATIONS:

- 1) TANK CAPACITY: 21,000 GAL (500BBL.)
- 2) TANK WEIGHT: 28,800 LBS. (EST.)

- NOTES:** THIS DRAWING IS A BASELINE REPRESENTATION FOR THIS MODEL TANK. VARIATIONS BETWEEN THE
1. DRAWING AND THE ACTUAL EQUIPMENT IN THE FIELD CAN AND DO EXIST, PRIMARILY WITH APPURTENANCE
LOCATIONS, SIZES AND QUANTITIES. CONSULT YOUR LOCAL BAKER REPRESENTATIVE IF SPECIFIC NEEDS EXIST.
2. THIS TANK IS TO BE TRANSPORTED WHILE EMPTY ONLY. IT IS NOT DESIGNED TO TRANSPORT LOADS.
3. MOST TANKS OF THIS TYPE HAVE AN INTERNAL LINING (COATING).

The information contained herein is proprietary to Baker Tanks and shall not be reproduced or disclosed in whole or in part, or used for any design or manufacture except when user obtains direct written authorization from Baker Tanks.				 3020 OLD RANCH PARKWAY SEAL BEACH, CA 90740-2751	
G				SCALE: Do Not Scale	SIZE B
F				DRAWN BY: V.A.W.	APPROVED BY: -
E				TITLE MODERN MFG. ROUND BOTTOM FIXED AXLE TANK - 500BBL	CAT/CLASS 110-1300
D				DRAWING NO. S-2-M0006-2-	SHEET 1 OF 1
C				REV. A	
B					
A	fixed text	7/12/05	ZER		
REV.	DESCRIPTION	DATE	BY		