

ITEM	QTY	DESCRIPTION
1	1	21" HINGED MANWAY
2	2	8" FLANGED NOZZLE (INLET & OUTLET)
3	1	4" FLANGED DRAIN
4	1	TOP ACCESS LADDER
5	1	REAR DOOR (GASKETED)
6	1	DOOR LOCKING MECHANISM
7	4	9" DIAMETER WHEELS
8	2	NOSE ROLLERS

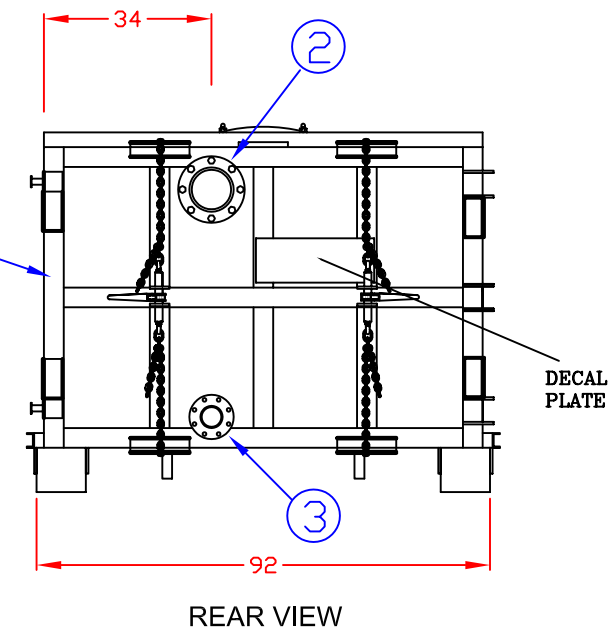
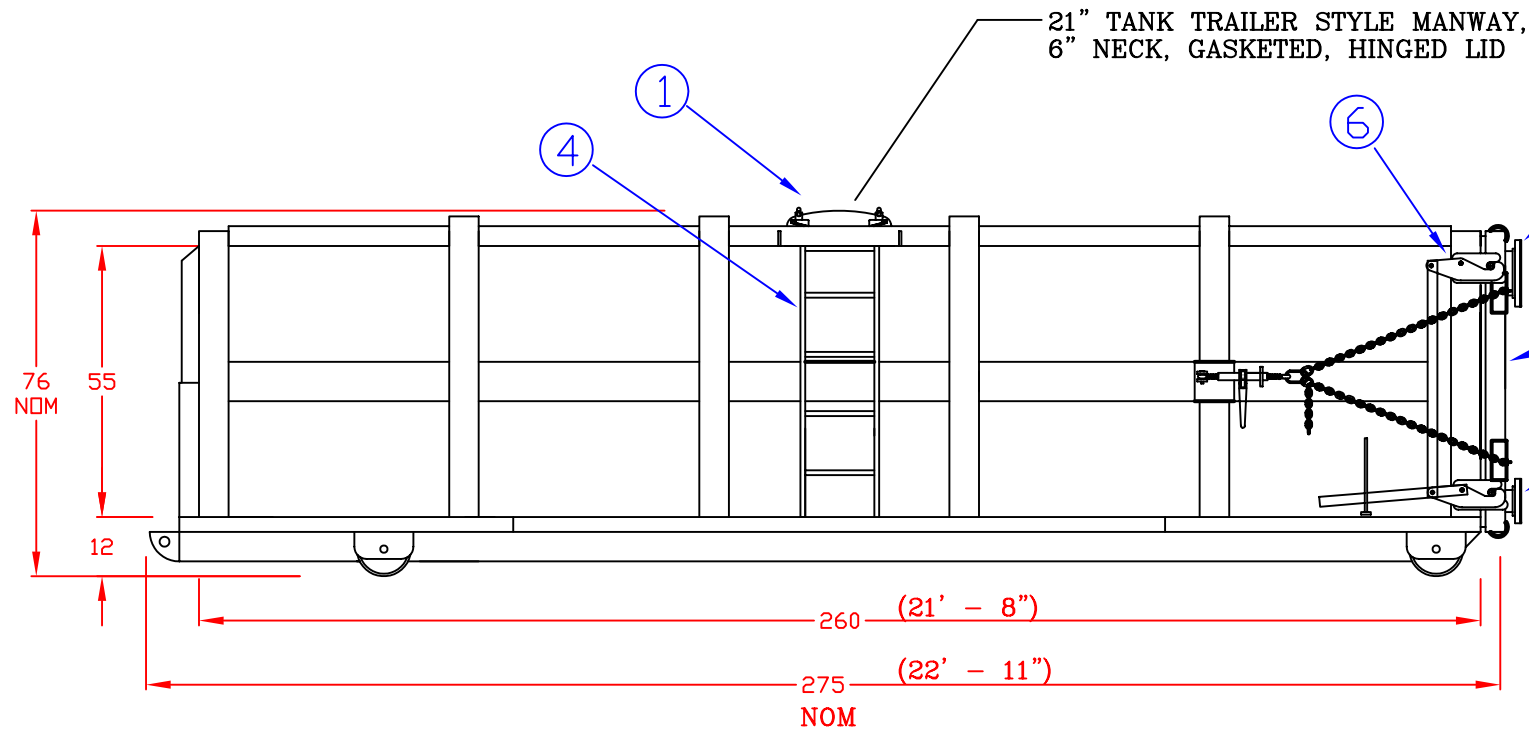

The information contained herein is proprietary to Baker Tanks and shall not be reproduced or disclosed in whole or in part, or used for any design or manufacture except when user obtains direct written authorization from Baker Tanks.

BAKER TANKS 3020 OLD RANCH PARKWAY
SEAL BEACH, CA 90740-2751

G				SCALE:	SIZE	ORIGINAL DWG. DATE
F				Do not scale	B	02AUG02
E				DRAWN BY:	APPROVED BY:	CAT/CLASS
D				P.J.B.	-	350-3000
C				TITLE		SHEET
B				MODERN MFG. VACUUM CONTAINER		1 OF 1
A				DRAWING NO.		REV.
REV.	DESCRIPTION	DATE	BY	S-5-M0005-1-		0

NOTES:
1. THIS DRAWING IS A BASELINE REPRESENTATION FOR THIS MODEL TANK. VARIATIONS BETWEEN THE DRAWING AND THE ACTUAL EQUIPMENT IN THE FIELD CAN AND DO EXIST, PRIMARILY WITH APPURTENANCE LOCATIONS, SIZES AND QUANTITIES. CONSULT YOUR LOCAL BAKER REPRESENTATIVE IF SPECIFIC NEEDS EXIST.