

**THIS DRAWING APPLIES TO TANKS
WITH EQUIPMENT NUMBERS
SFVP8322LM - SFVP8330LM**

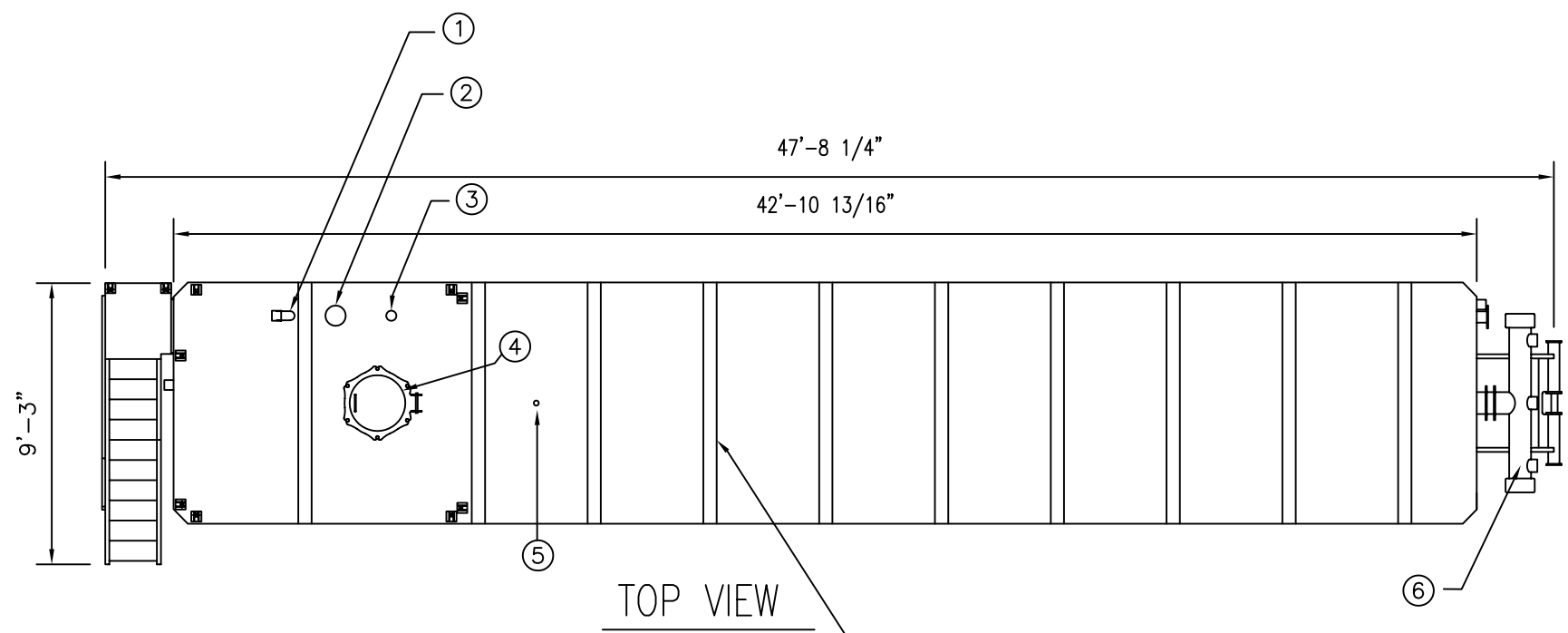

ITEM	QTY	DESCRIPTION
1	1	3" 90 deg. ell with cap and chain (Fill)
2	1	Press. (16 oz/sq.in.)/Vac. (0.4 oz/sq.in.) vent valve
3	1	4" Blind flange (vapor recovery conn.)
4	3	22" Manway with Buna-N gasket
5	1	2" Coupling with plug
6	1	8" Manifold w/(3) 4" thd. collars w/ plug & chain
7	1	4" Gel line w/ inlet butterfly valve & 45 deg. outlet
8	1	3" Overflow with thd. cap & chain

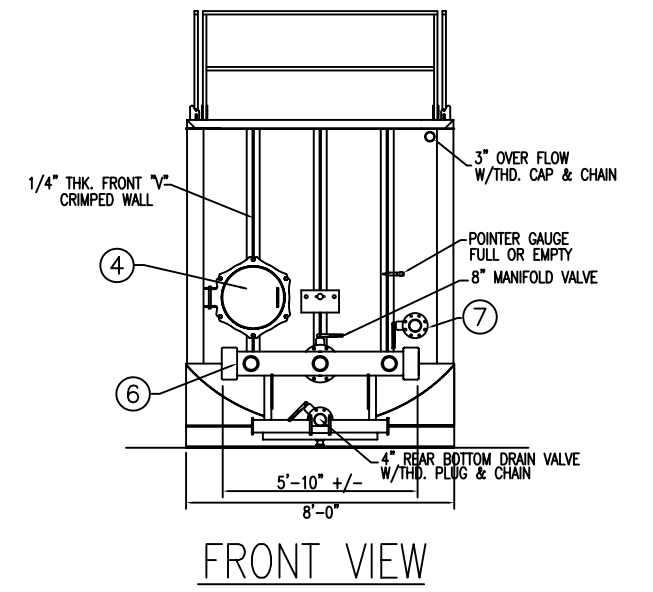
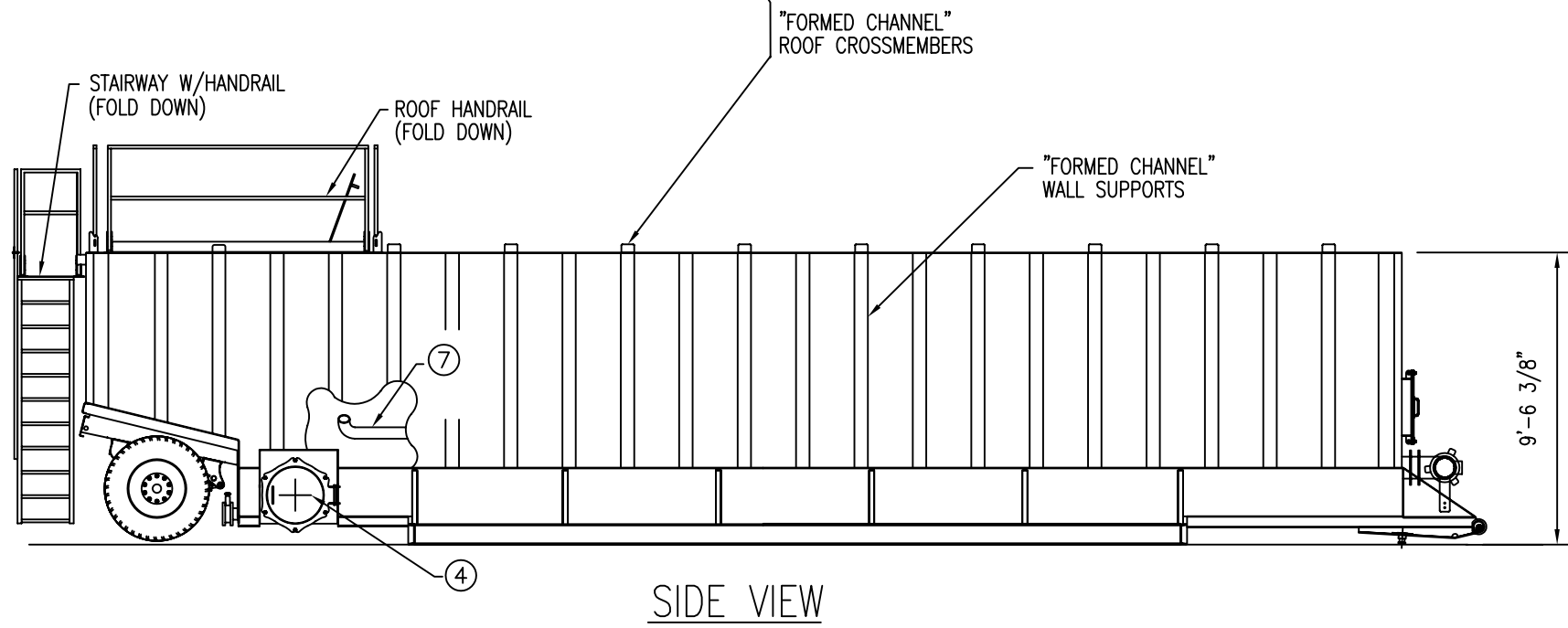
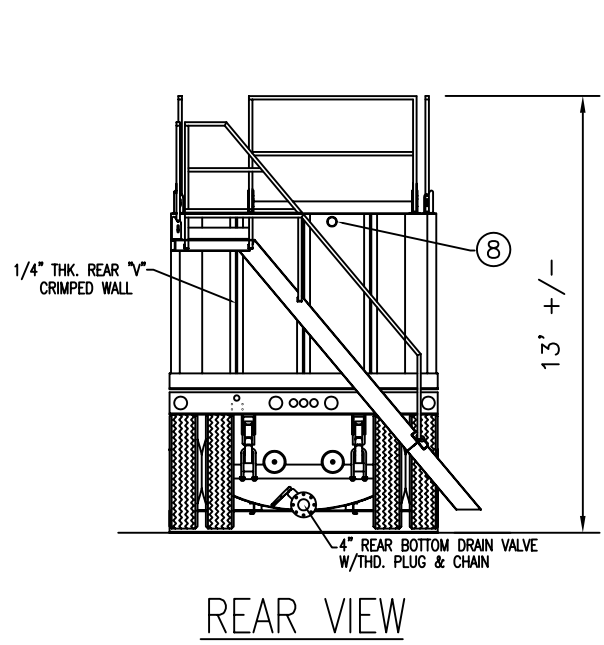

SPECIFICATIONS:
1) TANK CAPACITY: 18,900 GAL (450 BBL.)

NOTES:
1. THIS DRAWING IS A BASELINE REPRESENTATION FOR THIS MODEL TANK. VARIATIONS BETWEEN THE DRAWING AND THE ACTUAL EQUIPMENT IN THE FIELD CAN AND DO EXIST, PRIMARILY WITH APPURTENANCE LOCATIONS, SIZES AND QUANTITIES. CONSULT YOUR LOCAL BAKER REPRESENTATIVE IF SPECIFIC NEEDS EXIST.
2. THIS TANK IS TO BE TRANSPORTED WHILE EMPTY ONLY. IT IS NOT DESIGNED TO TRANSPORT LOADS.
3. MOST TANKS OF THIS TYPE HAVE AN INTERNAL LINING (COATING).

<p>The information contained herein is proprietary to Baker Tanks and shall not be reproduced or disclosed in whole or in part, or used for any design or manufacture except when user obtains direct written authorization from Baker Tanks.</p>						<p>3020 OLD RANCH PARKWAY SEAL BEACH, CA 90740-2751</p>		
G				SCALE:	SIZE	ORIGINAL DWG. DATE		
F				Do Not Scale	B	17SEP02		
E				DRAWN BY:	APPROVED BY:	CAT/CLASS		
D				P.J.B.	-	110-1250		
C				TITLE				SHEET
B				WADE SINGLE WALL FIXED AXLE TANK WITH GEL LINE & MANIFOLD				1 OF 1
A				DRAWING NO.				REV.
REV.	DESCRIPTION	DATE	BY	S-2-M0010-1-0				