

FRONT VIEW

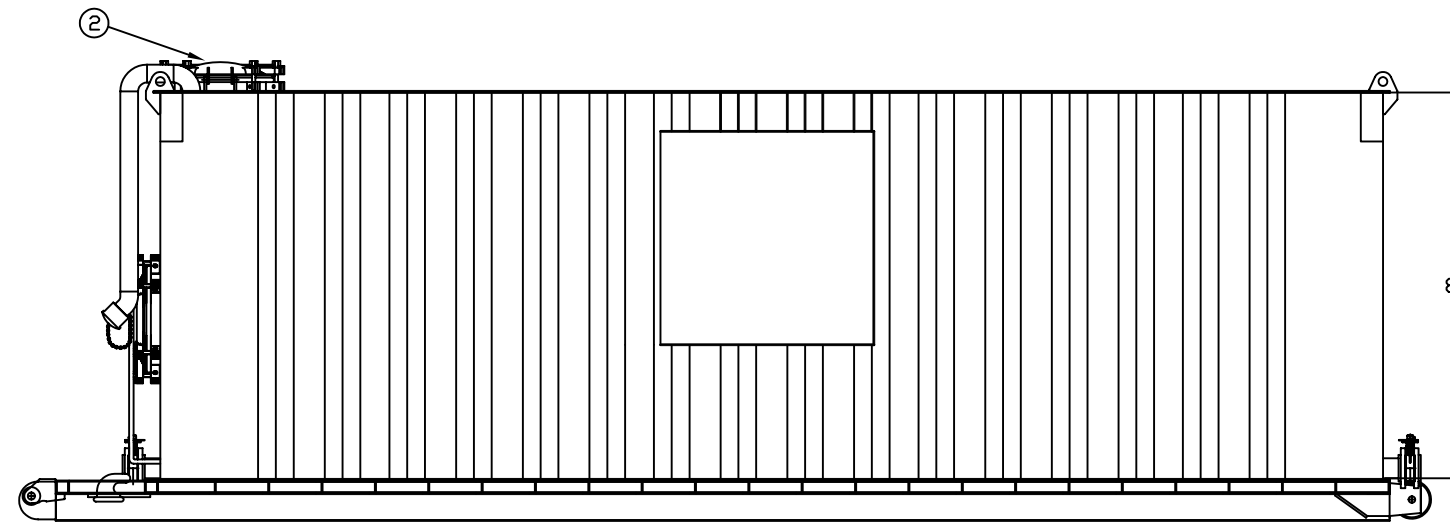

DRIVER'S SIDE ELEVATION

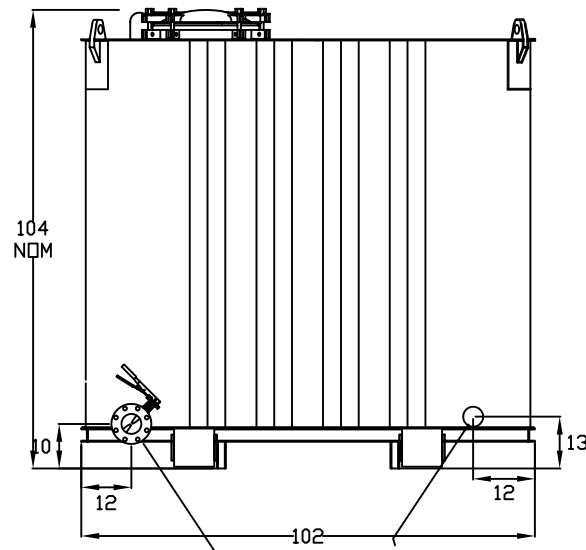

REAR VIEW

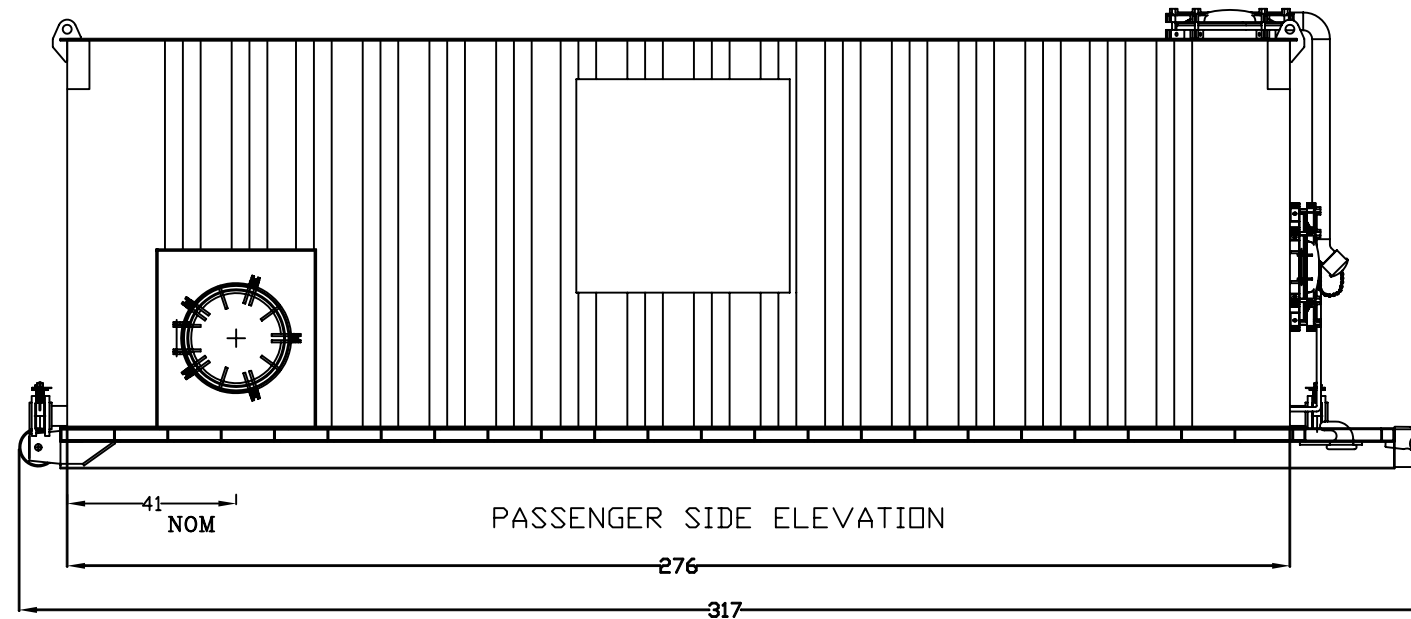

PASSENGER SIDE ELEVATION

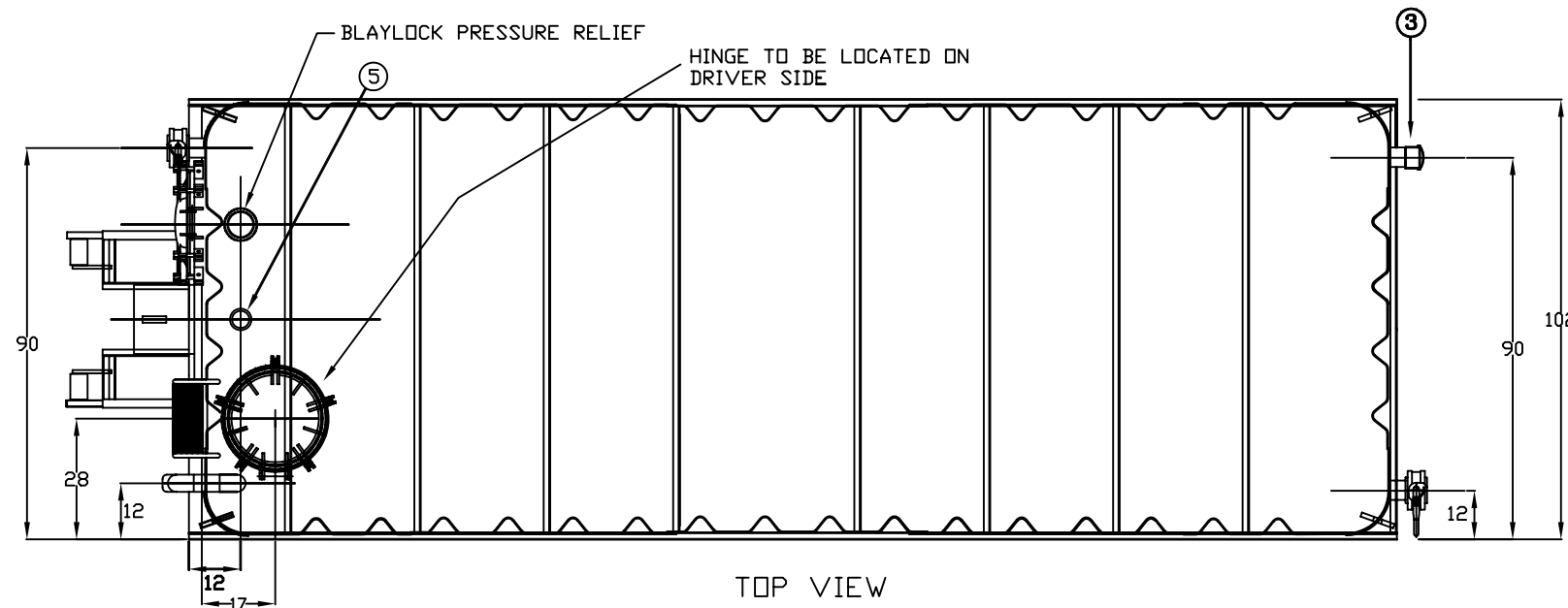

TOP VIEW

ITEM	QTY	DESCRIPTION
1	3	4" 150# threaded flange with cap & chain
2	3	21" manway
3	2	4" NPT male with cap & chain
4	1	3" NPT male with cap & chain (fill line)
5	2	4" half coupling with plug & chain

NOMINAL WEIGHT: 12,700 lbs.

NOMINAL CAPACITY: 10,000 gal.

NOTES:

1. This drawing is a baseline representation for this model tank. Variations between this drawing and the actual equipment in the field can and do exist, primarily with appurtenance loactions, sizes and quantities. Consult your local Baker representative if specific needs exist.
2. This tank is constructed of A36 carbon steel.

<p>The information contained herein is proprietary to Baker Tanks and shall not be reproduced or disclosed in whole or in part, or used for any design or manufacture except when user obtains direct written authorization from Baker Tanks.</p>						<p>3020 OLD RANCH PARKWAY SEAL BEACH, CA 90740-2751</p>	
G		SCALE:	SIZE	ORIGINAL DWG. DATE			
F		Do Not Scale	B	31JUL02			
E		DRAWN BY:	APPROVED BY:	CAT/CLASS			
D		P.J.B.	-	170-4xxx			
C		TITLE	SHEET				
B		MODERN MFG. 10K TANK	1 OF 1				
A		DRAWING NO.	REV.				
REV.	DESCRIPTION	DATE	BY	S-9-M0002-1-0			