

PRODUCT DATA SHEET

April, 2003

3" JTV3G60 GORMAN-RUPP ELECTRIC SUBMERSIBLE PUMP

GENERAL INFORMATION

Electric motor driven solids handling "vortex" style pump. The pump rests on a stand to elevate the volute which allows flow into the impeller.

PERFORMANCE DATA

➤ Operating Speed:	- 1750 RPM
➤ Shutoff Head :	- 67' (29 psi) ⁽¹⁾
➤ Minimum Flow:	- 50 GPM
➤ Maximum Flow:	- 525 GPM
➤ Max. Submergence:	- 65 feet
➤ Max. Liquid Temp.:	- 104° F
➤ Maximum Solids Size:	- 3.15" Diameter

PUMP SPECIFICATIONS

➤ Impeller:	- 8.78" diameter
➤ Mechanical Seals:	- Oil lubricated double: <u>Upper</u> - silicon carbide rotating face, carbon stationary face, Viton elastomers <u>Lower</u> - silicon carbide rotating face, silicon carbide stationary face, Viton elastomers
➤ Suction Strainer:	- None - rests on a stand

PHYSICAL SPECIFICATIONS

➤ Discharge Size:	- 3" barbed hose connector
➤ Total Weight:	- 192 lbs. (pump only) 198 lbs. (w/std. cable)
➤ Height:	- 30" (bottom of stand to top of bail) 12-1/2" (bottom of stand to top of discharge connector)
➤ Width:	- 12" (O.D. - pump only) 19-1/2" (plan view footprint from discharge connector to O.D. of stand)

MATERIAL SPECIFICATIONS

➤ Volute Casing:	- Gray Iron No. 30
➤ Motor Housing:	- Gray Iron No. 30
➤ Impeller:	- Ductile Iron No. 80-55-06
➤ Seal Housing:	- Gray Iron No. 30
➤ Motor Shaft:	- Stainless Steel No. 329
➤ O-rings:	- Buna-N

ELECTRICAL SPECIFICATIONS

➤ Electric Motor:	- 6.2 H.P., 1750 RPM, air filled enclosure. 460 volt 3-phase, 60 Hz, 9.8 full load AMPS, NEMA Code G, 1.15 Service Factor
➤ Power Cable:	- Neoprene jacketed; single cable, 14 AWG., 7 wire conductors (2 conductors used for moisture and thermal protection)
➤ Standard Features:	- Moisture sensor switch, thermal protection switches, across-the-line motor wiring connection

Notes:

⁽¹⁾ Based on 1.0 specific gravity

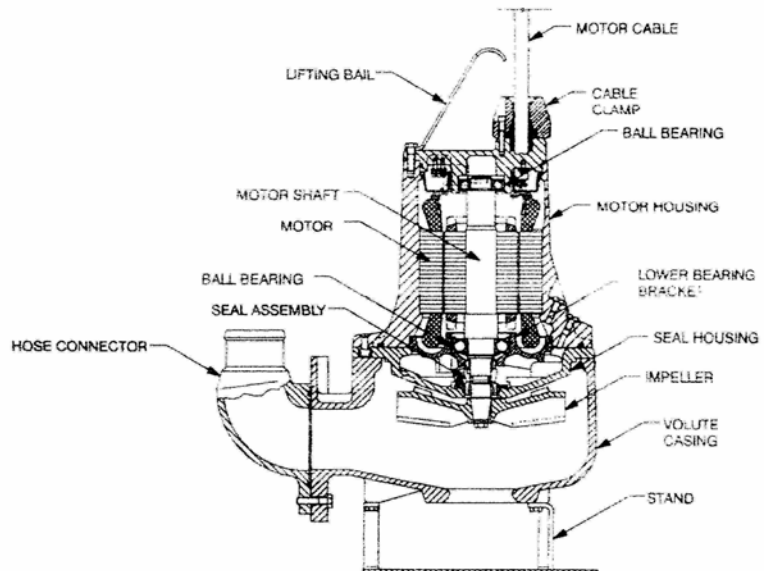

To the best of our knowledge the technical data contained herein are true and accurate at the date of issuance and are subject to change without prior notice. No guarantee of accuracy is given or implied because variations can and do exist. NO WARRANTY OR GUARANTEE OF ANY KIND IS MADE BY BAKER PUMPS, EITHER EXPRESS OR IMPLIED.